

KNOCK-OUTS

To accommodate fans or wire pass through, there are (2) 120mm-diameter cut hole patterns in both the top and bottom plates of the rack. To remove, simply use a hammer to knock the plates out and remove. Do not remove more than one knockout from each plate.

** If running wires through holes is needed when stacking two racks together, remove the same knockout from both the top and bottom plates.*

OPTIONAL FEET (Included with Rack Hardware)

Also included are 4 hard plastic, stationary feet. If casters are not desired, simply unscrew casters and use stationary feet instead.

CAUTION - feet may damage flooring if rack is moved when loaded with equipment.

ACCESSORY INSTALLATION

- Determine the layout of your components, their space requirements and where you will place vents or blanks.
- Unbox your first shelf, starting with the one you will place at the bottom of the rack. The heaviest components should be placed as low as possible.
- Unfold shelf side panels and mount in desired rack location using four Strong™ rack screws. Accessory mounting screws are not included with shelves, vents or blanks (only with racks).
- Install component onto shelf.
- Unbox and install the next shelf, vent or blank following the above steps.

A vent should be placed above components that generate excessive heat, such as surround receivers, amplifiers, satellite receivers, DVR's, cable boxes and media servers.

NEED RACK SCREWS?

Screws are not included with our rack accessories, but extra screws are available (SR-SCREWS-200JAR). One no-roll jar includes 200 black 10/32 screws featuring #2 Phillips heads and captive nylon washers.



Lifetime Limited Warranty

All Strong™ products have a Lifetime Limited Warranty. This warranty includes parts and labor repairs on all components found to be defective in material or workmanship under normal conditions of use. This warranty shall not apply to products which have been abused, modified or disassembled. Products to be repaired under this warranty must be returned to SnapAV or a designated service center with prior notification and an assigned return authorization number (RA).

For Technical Support : 1.866.838.5052



engineered by
Snap
av

ASSEMBLY MANUAL

CONTRACTOR SERIES RACKS

SR-CS-RACK-12U

SR-CS-RACK-16U

SR-CS-RACK-21U



Strong™ CONTRACTOR SERIES RACKS

Strong™ equipment racks are solid steel and feature fully enclosed steel side panels. They are available in three sizes: 12-space, 16-space and 21-space. The racks are set upon 4 heavy-duty, 3-inch (75 mm) rubber casters with locking fronts. Each equipment rack includes a 1U blank panel for support on the back side of rack. The unique front and back pillar construction allows the racks to be assembled to accept either Metric or English Standard thread sizes. The inside of each pillar has a removable sticker which points to the corresponding thread pattern - Metric (to use M6 rack screws) or English Standard (to use 10/32 rack screws).

RACK SIZE OPTIONS

Equipment racks are available in three sizes:

- 12 space
- 16 space
- 21 space.

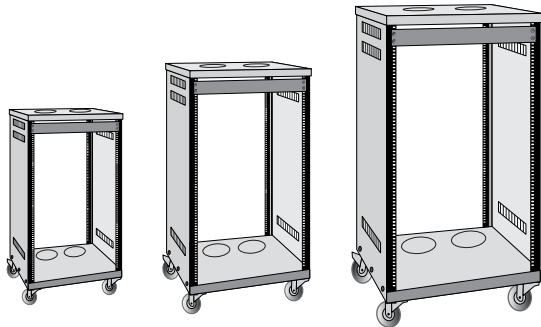

SR-CS-RACK-12U

SR-CS-RACK-16U

SR-CS-RACK-21U

MODEL	DEPTH	RACKING HEIGHT	W/ CASTERS HEIGHT	WIDTH
	"A"	"B"	"C"	"D"
SR-CS-RACK-12U	18.11"	23.62"	27.55"	19.96"
SR-CS-RACK-16U	18.11"	30.70"	34.65"	19.96"
SR-CS-RACK-21U	18.11"	39.37"	43.31"	19.96"

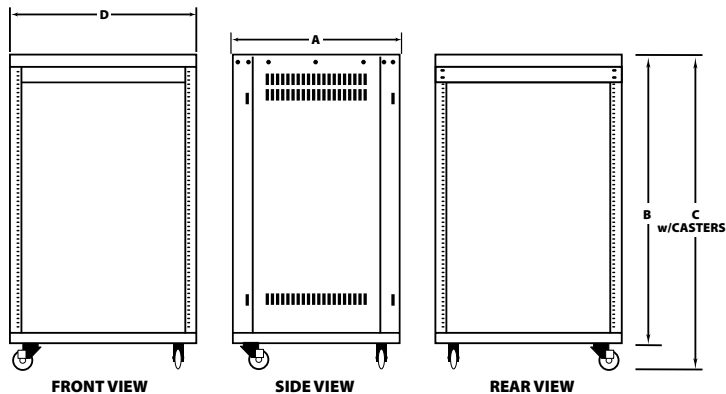

PARTS INCLUDED

1. Top Plate
2. Side Plate
3. Front Pillar
4. Back Pillar
5. Base Plate
6. Casters (4)
7. Rack Assembly Screws
8. 1U Blank Plate

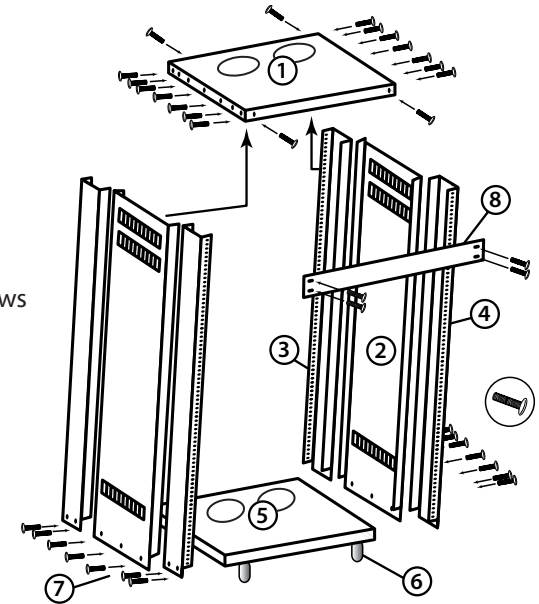

RACK ASSEMBLY

Lock the casters before starting assembly.

- First ensure that the four pillars are arranged with threaded screw holes facing outwards.

Note: Sticker on inside of each pillar points to the location of Metric and English Standard thread pattern.

With the base plate (part #5) flat on the ground, use three of the supplied rack assembly screws (part #7) to attach each side plate (part #2) so that the inner flange is flat against the base plate.

- On either side of each side plate, screw in the bottom of the pillars using two rack assembly screws (part #7) per pillar (parts #3 and #4) with the inner flange sitting flat against the base. One side of the threaded screw holes in each pillar should be facing outwards, either Metric or English Standard.
- Place the top plate (part #1) over the sides of the rack so that the four pillars and side plates fit inside the top plate and attach using eighteen supplied rack assembly screws. For extra stability, install 1U Blank Plate (part #8) to upper most position on back side of the rack.

CAUTION:



This rack is intended for use only with shelf models SR-SHELF-2U,-3U,-4U, and -5U with a maximum combined load of 600 pounds. Use with heavier than the maximum load indicated may result in instability causing possible injury.